

## 180kVA Diesel Engine Driven GPU Deutz Diesel



### HOBART: “A NAME YOU CAN TRUST”

Hobart offers the best combination of superior design, performance, proven reliability, and value to meet the critical needs of the airline industry with our series of modern ground power units. Integrating the *best in technology, customer influenced design* and Hobart’s years of *engineering expertise*, our Ground Power Units can be trusted to meet your aircraft’s needs for quality 400Hz power.

### DESIGNED FOR DURABILITY:

Low profile, combined with standard 5th wheel (turntable) steering, provides superior visibility and maneuverability in congested ramp areas, while the durable bumper system protects the unit from damage caused by other GSE.

### POWER FOR PEAK PERFORMANCE:

The Hobart Deutz diesel powered GPU features the BF6M1013FC electronically controlled diesel engine, combined with a *Hobart designed and manufactured* generator, to maximize GPU performance while maintaining the traditional Hobart reputation for reliability.

### CE CERTIFIED:

CE certification and international labeling are added features of this GPU.

### PERFORMANCE FEATURES

- Emission Certified Engine (Tier 2)
- Noise “Isonorized” design with optional noise reduction kit
- Large corrosive free fuel tank (125 gallon) and low fuel warning shutdown are **standard**
- Delayed stop (for turbo protection) and emergency shutdown are **standard**
- Hobart-designed and manufactured generator offers long life and reliability
- Deutz fuel/water separator is **standard**
- Numbered, color-coded wiring remains traceable for the life of the unit
- 5th wheel (turntable) steering features maintenance-free nylon bushings
- Choice of drum type braking systems: tow bar activated or hand brake activated
- Superior regulation via the engine’s electronic control module
- Lift-off doors and pop-out panels provide easy access to engine, generator and control compartments
- Lost Neutral Detection is **standard**

Type	kVA	kW	Outputs	Engine Model	HP	Unit Weight
Trailer	180	144	2	BF6M1013FC	276	7000 lbs (3175 kg)
Fixed						6500 lbs (2948 kg)

# Hobart Deutz Diesel Engine Driven Ground Power Unit

## Specifications

### Engine

- Deutz BF6M1013FC diesel engine operating at 2000 RPM (276 hp)
- Turbocharged 4-stroke, inline 6 cylinder, charge air cooled
- Full application approval by Deutz Corp.
- 12VDC battery system
- Low oil pressure shutdown
- High coolant temperature shutdown
- Intake air restriction indication
- Electronic governor system (via the engine's ECM)
- Semi-automatic engine pre-heater for cold weather starts

### Environmental

- Relative humidity 0-100% non-condensing
- No altitude derating required up to 5,000 feet, when running in normal operating range

### Performance

- Rating: 180 kVA, 3 phase, 4 wire, 115/200 VAC, continuous
- Meets or exceeds MIL-STD-704F Electrical Power Quality Requirements

### Overload

- 110% rated load for 5 minutes
- Individual outputs: 324 amps, 5 minutes

### Voltage

- Transient voltage recovery time: to within  $\pm 1\%$  in 100 milliseconds (no load to rated load)
- Within  $\pm 20\%$  deviation upon application/removal of 100% load rating
- Modulation: does not exceed 0.5% of steady state voltage
- Phase voltage displacement with balanced load:  $120 \pm 1.5$
- Phase voltage balance (with unbalanced load) does not exceed 4% with 1/3 rated current on any single phase with other two phases disconnected
- Crest factor:  $1.414 \pm 0.07$

- Individual Harmonic Distortion:  $< 2\%$  of the fundamental (RMS) voltage
- Total Harmonic Distortion:  $< 3\%$  of the fundamental (RMS) voltage

### Regulation

- Voltage Regulation:  $\pm 1\%$  no load to full load
- Voltage adjust:  $\pm 15$  volts
- IHD (individual harmonic content):  $< 2\%$
- Three phase average sensing
- Line Drop Compensation: Automatic up to 5%

### Frequency

- Regulation:  $\pm 2$ Hz steady rate
- Transient recovery: to within  $\pm 5$ Hz in  $< 2$  seconds per ARP 5015A
- Modulation:  $< 0.25\%$  (1Hz)

### Protection

- Meets MIL-STD-704F
- Over-voltage: instantaneous disconnect of load at 180 volts L-N, with inverse time delay down to 126 volts in 2 seconds
- Under-voltage: disconnects output below 100 volts L-N in 7 seconds
- Over-frequency: disconnects output above 420Hz in 5 seconds
- Under-frequency: disconnects output below 380Hz in 7 seconds

### Finish

- Anti-corrosive Polyester powder provides excellent weather resistance, flexibility and adhesion, plus a strong resistance to chemical agents such as glycol and skydrol
- Standard colors are high gloss white over black frame and chassis
- Custom colors require a paint chip or swatch for accurate color match

### Trailer

- Tire Size: 20.5 x 8.00 -10
- Ground clearance: 9.5 in. (241.3mm)
- Brakes: Tow bar activated, drum type

## Displays / Instrumentation

### Engine Operation

- **Meters:** coolant temperature, battery voltmeter, hour meter, oil pressure, fuel level
- **Indicator Lights:** engine circuit on, engine stop delay action, panel lights, fault summary (test/reset button)
- **Fault Code Display:** air cleaner restriction, high coolant temperature, low oil pressure, low fuel warning, etc.
- **Buttons:** Engine start, engine stop, panel lights, cold start intake heater

### Generator Output

- **Meters:** frequency, ammeter, voltmeter
- **Indicator Lights:** contactors on, fault summary (test/reset button), EF interlock mode
- **Fault Code Display:** over-frequency, under-frequency, overload, over-voltage, under-voltage, etc.
- **Buttons:** meter select, output contactors control, test/reset

### Available Options:

- Block heater kit, (120V/60Hz or 240V/50Hz)
- Internal 28.5 VDC Transformer-Rectifier (600 A continuous, 2000 A peak)
- Automatic towbar height stop
- Pintle or pin hitch
- Spot light
- Stainless Steel Fuel Tank
- Alternative mounting configuration: stationary, fixed, or truck mounted
- Special paint scheme
- Hand activated brakes
- Battery blanket (120V)
- Indicator beacons (low fuel, operating)
- Low fuel warning/shutdown
- Clearance lights
- CE marking

*Specifications are subject to change without notice.*

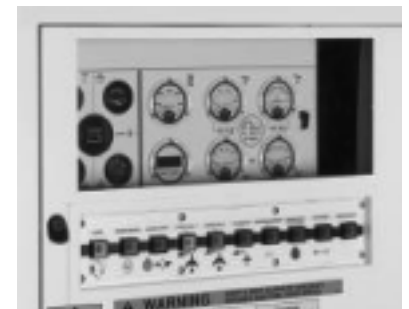
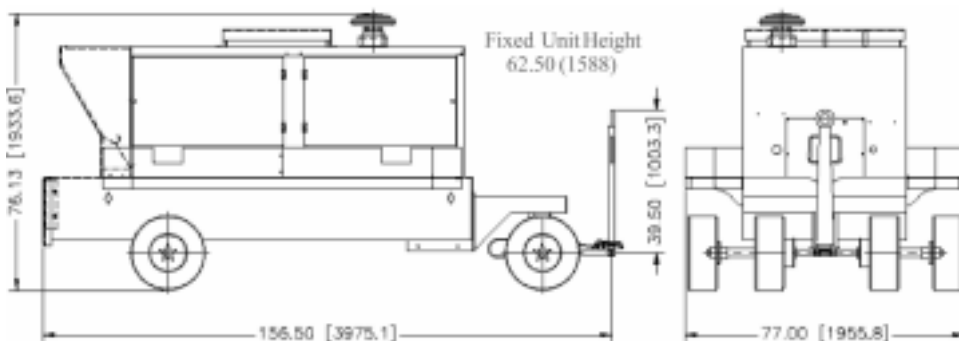

**Hobart Ground Power** • Headquarters & Factory: 1177 Trade Road East, Troy, OH 45373 U.S.A.  
Phone: 1-800-422-7253 or 937-332-5080 • Fax: 937-332-5799  
E-mail: hgpsales@itwgsegroun.com • www.hobartgroundpower.com

**Hobart Asia Office** • Phone: + 853 288 81 891 • Fax: + 853 288 81 891

**Hobart International (UK)** • Phone: 44-1723-370437 • Fax: 44-1723-370125

An Illinois Tool Works Company